



UNIVERSITY OF CAMBRIDGE INTERNATIONAL EXAMINATIONS
General Certificate of Education Ordinary Level

PHYSICS

5054/03

Paper 3 Practical Test

October/November 2008

CONFIDENTIAL INSTRUCTIONS

Great care should be taken to ensure that any confidential information given does not reach the candidates either directly or indirectly.

No access to the Question Paper is permitted in advance of the examination.



If you have any problems or queries regarding these Instructions, please contact CIE
by e-mail: International@cie.org.uk,
by phone: +44 1223 553554,
by fax: +44 1223 553558,
stating the Centre number, the nature of the query and the syllabus number quoted above.

This document consists of **11** printed pages and **1** blank page.



Instructions for preparing apparatus

These instructions detail the apparatus required for each experiment in this paper. No access is permitted to the Question Paper in advance of the examination session.

Number of sets of apparatus

In addition to a few spare sets, the minimum number of sets of apparatus to be provided should be sufficient to enable candidates to spend 20 minutes with the apparatus for each of Questions 1, 2 and 3, and one hour with the apparatus for Question 4. The order in which candidates answer the questions will be determined by the Supervisor. Candidates may spend one hour circulating around Questions 1, 2 and 3, followed by an hour on Question 4, or vice versa.

Extra graph paper should be available. It is assumed that candidates will supply their own calculator and geometrical instruments, such as a set square, 0° to 180° protractor, pair of compasses and 30 cm rule. Candidates should be advised in advance that they may, if they wish, use quartz wristwatches with stopwatch facilities, providing that such wristwatches afford the required precision.

Instructions for the supervision of the examination

The Supervisor, who may be a Physics teacher, is responsible for the administration of the examination according to the procedures detailed in the Handbook for Centres. In all instances, a Physics teacher should be present. Preferably, this teacher should have been responsible for the preparation of the apparatus. Two invigilators must be present at all times: it is not acceptable for a teacher who has been responsible for preparing the candidates for this paper to be the sole Supervisor or Invigilator.

Supervisors may make the following announcement at the start of the examination.

'The Examiners do not want you to waste time when you are unable to do any experiment. Any candidate who is unable to get results with an experiment may ask for help. The extent of this help will be reported to the Examiners, who may make a deduction of marks.'

Supervisors should note that a candidate may only be given enough assistance to allow some raw readings or observations to be made. On no account should any assistance be given with the treatment or analysis of these readings and observations.

Supervisors may draw to the attention of the candidates any significant deviation between the apparatus provided and that detailed in the Question Paper, particularly where diagrams are given in the paper.

Candidates should be reminded that all their work should be written on the printed Answer Booklet. Rough paper must not be used.

The Supervisor must complete the Report at the back of these Instructions. Details should be given of any significant deviation between the apparatus used and that specified in these Instructions. A sample set of results can often help Examiners. A copy of this Report must be included in **each** packet of scripts.

1 Items to be supplied by the Centre (per set of apparatus, unless otherwise specified)

Slit to act as an object.

Lamp, connected to suitable power source, to illuminate the object.

White screen of approximate dimensions 20 cm by 20 cm.

250 cm³ transparent glass or perspex beaker filled with water.

Metre rule with a millimetre scale.

Set square.

Notes

- (i) The slit should be formed by using a 20 cm square piece of card or board. A slit should be made in the card, passing vertically upwards from the centre of the base of the card. The height of the slit should be equal to the height of the beaker and its width should be between 1 mm and 2 mm. A piece of tracing paper should be taped across the back of the slit.
- (ii) The card and the screen should be supported so that they can stand perpendicular to the bench. This should be done by attaching blocks of wood to the base of the card and the screen. The slit must not be obscured so two blocks should be used, one each side of the slit. This is shown in Fig. 1.1.

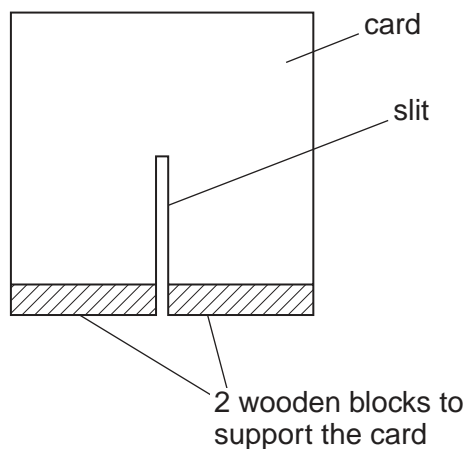

Fig. 1.1

- (iii) The apparatus should be in a dimly lit area of the laboratory and the lamp should be bright enough so that candidates can see an image formed on the screen.
- (iv) The **candidate** is to set up the apparatus as shown in Fig. 1.2.

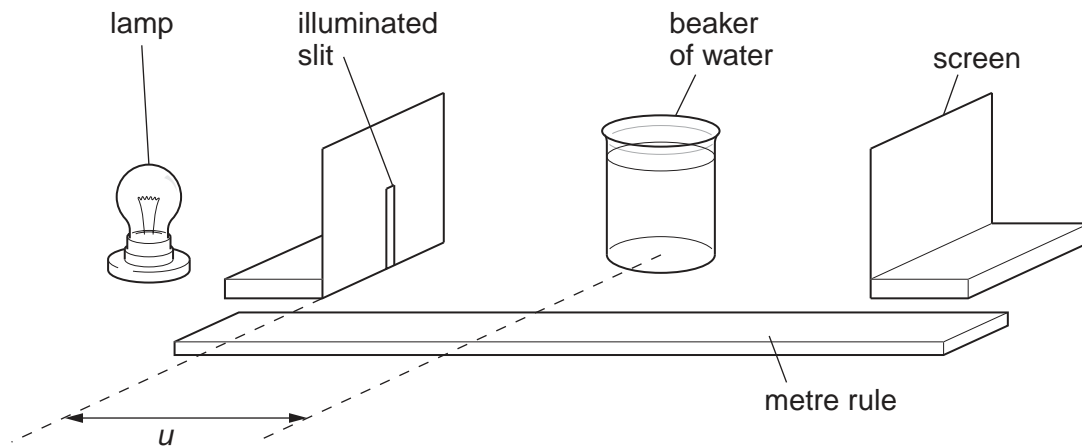

Fig. 1.2

- (v) At the changeover, the Supervisor should dismantle any apparatus that has been left set up by the candidate.

Information required by examiners

None.

2 Items to be supplied by the Centre (per set of apparatus, unless otherwise specified)

Pulley wheel mounted approximately 1.3 m above the floor.

50 g mass labelled A.

60 g mass labelled B.

1.5 m of strong thin thread.

Metre rule with a millimetre scale.

Stopwatch reading to 0.1 s or better.

Notes

(i) Supervisors should assemble the apparatus as shown in Fig. 2.1.

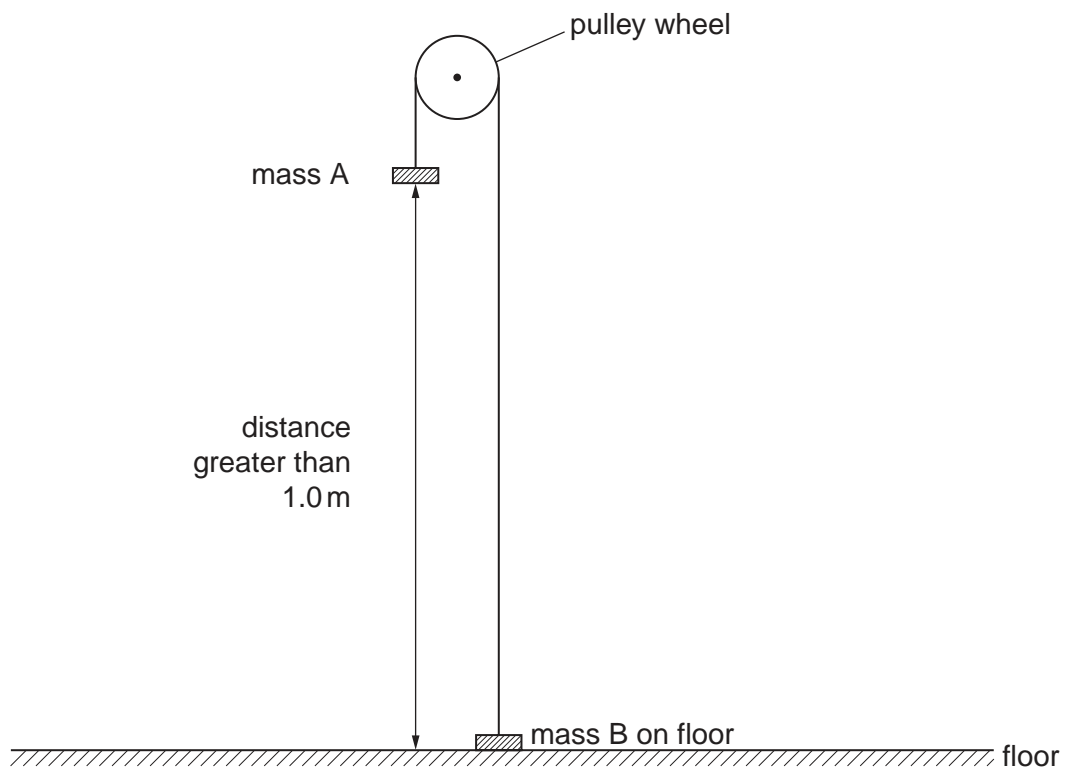

Fig. 2.1

- (ii) When mass B is resting on the floor, mass A should be more than 1.00m above the floor.
- (iii) The pulley wheel may be of any type. It must be mounted or suspended securely, which may require the use of a stand, boss and clamp, as shown in Fig 2.2.

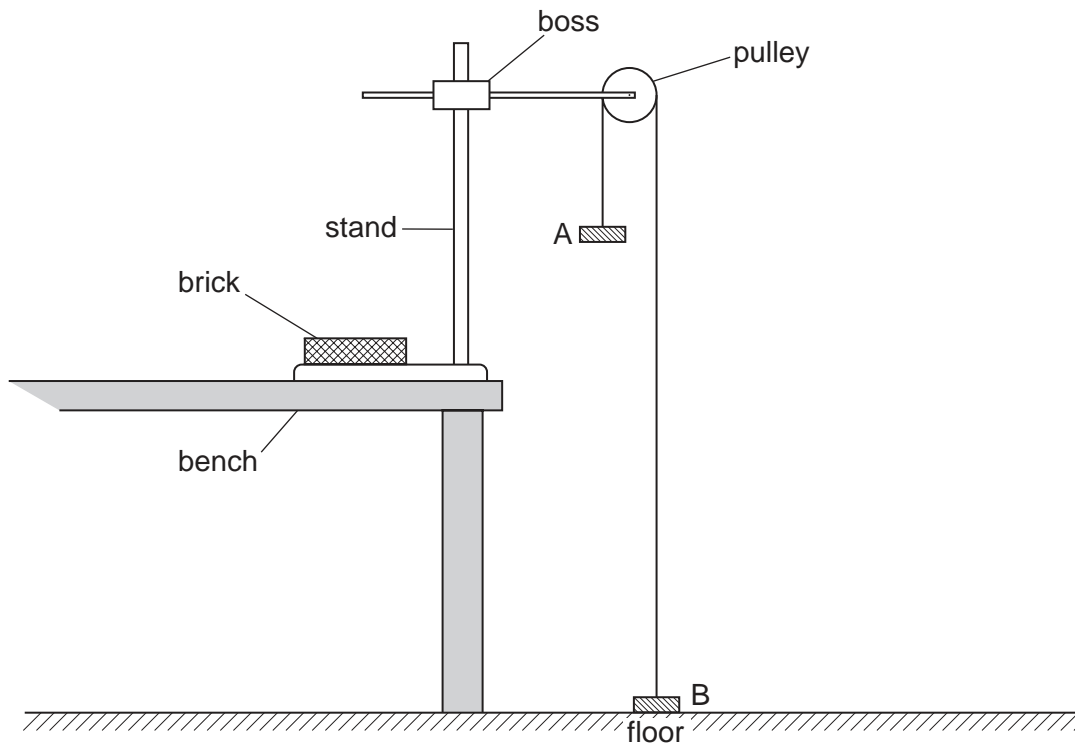

Fig. 2.2

The pulley wheel should lie in a vertical plane. It should turn freely, allowing mass B to fall to the floor without hitting mass A.

- (iv) At the changeover, the Supervisor should check that the apparatus is still set up as shown in Fig. 2.1.

Information required by examiners

None.

3 Items to be supplied by the Centre (per set of apparatus, unless otherwise specified)

3 V d.c. power supply, e.g. two 1.5 V dry cells in a suitable holder.

Light dependent resistor (NORP 12 is suitable).

470 Ω resistor.

Switch or plug key.

Milliammeter capable of recording current to a precision of at least 0.1 mA. A 10 mA analogue or a 20 mA digital meter will be suitable.

Voltmeter capable of recording potential difference to a precision of at least 0.1 V.

Five connecting leads to enable the Supervisor to connect the circuit shown in Fig. 3.1.

Two further connecting leads.

Paper or cardboard disc to cover the LDR.

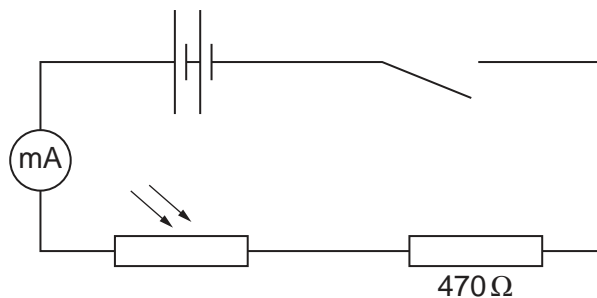

Fig. 3.1

Notes

- (i) Supervisors should set up the circuit shown in Fig. 3.1.
- (ii) The milliammeter should not go off scale when the LDR is illuminated with the normal background light in the laboratory. If necessary the value of the resistor or the power supply should be changed so that the meter reading is not off scale.
- (iii) The thickness of the disc should be such that the current is reduced significantly when the LDR is covered by the disc.
- (iv) The two additional leads should be connected to the voltmeter so that it may easily be connected across the LDR by the candidate.
- (v) At the changeover, the Supervisor should remove the voltmeter from the circuit, remove the disc from on top of the LDR and check that the circuit is still connected as in Fig. 3.1.

Information required by examiners

None.

4 Items to be supplied by the Centre (per set of apparatus, unless otherwise specified)

Wooden metre rule with a millimetre scale.

Two identical expendable steel springs e.g. Griffin XBV–590–010H.

Round flat-headed nail of approximate length 10 cm and diameter 3 mm.

Stand and boss to support the nail horizontally.

Boss and clamp to hold the lower end of one of the springs as shown in Fig. 4.1.

String.

Second metre rule with a millimetre scale.

Set square.

50 g mass labelled A, with loop of thread attached.

Notes

- (i) A hole should be drilled in the wooden metre rule at the 15.0 cm mark.
- (ii) The diameter of the hole should be slightly greater than the diameter of the nail so that the rule pivots freely on the nail. An alternative method of pivoting the rule is acceptable provided that the pivot is strong enough.

- (iii) The loop of thread attached to mass A should be sufficiently long to enable the mass to be moved along the rule when suspended from it.

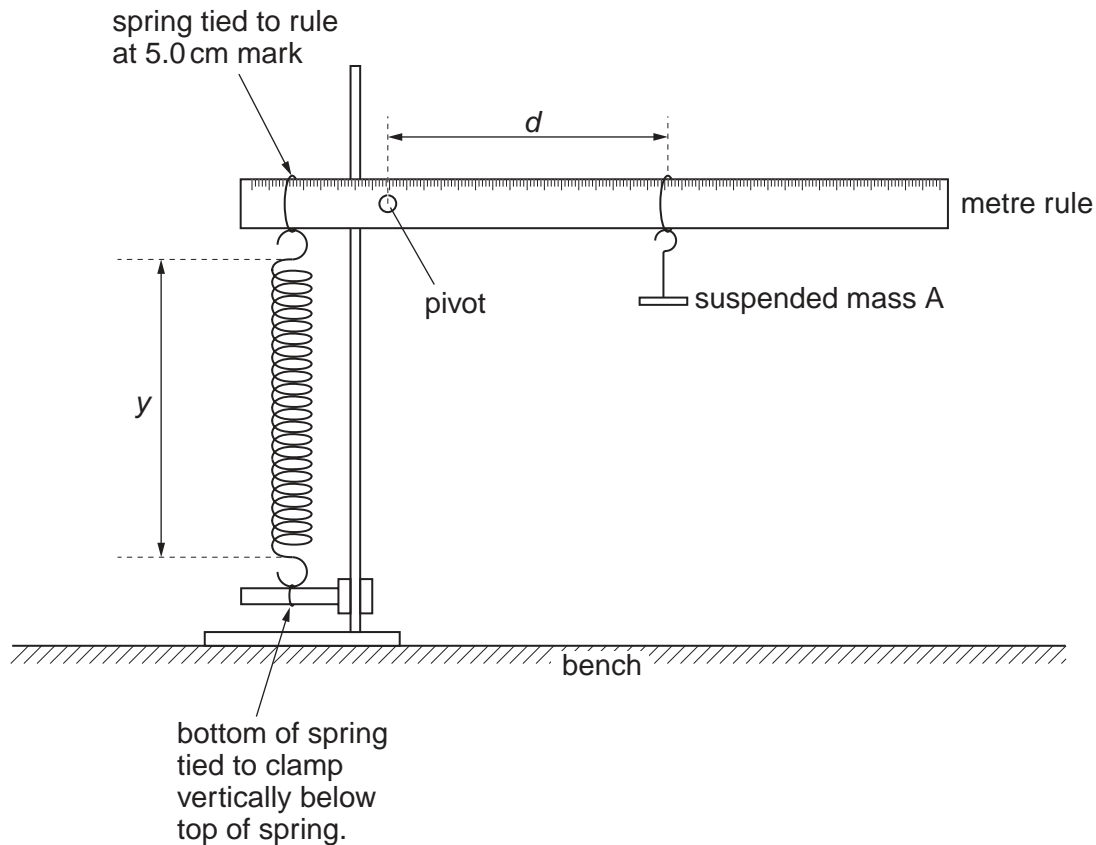

Fig. 4.1

- (iv) The apparatus should be set up by the Supervisor as shown in Fig. 4.1. The nail should pass through the hole at the 15.0 cm mark and should be held in the boss on the stand. The boss should be about 40 cm above the bench. The rule should be approximately horizontal and mass A should be suspended from the 60 cm mark on the rule.
- (v) If mass A cannot be suspended from the 60 cm mark without over-stretching the spring, then the value of the mass should be reduced.
- (vi) At the changeover, the mass should be returned to the 60 cm mark on the rule and the height of the clamp holding the bottom of the spring should be adjusted so that the rule is **approximately** horizontal.

Information required by examiners

None.

Permission to reproduce items where third-party owned material protected by copyright is included has been sought and cleared where possible. Every reasonable effort has been made by the publisher (UCLES) to trace copyright holders, but if any items requiring clearance have unwittingly been included, the publisher will be pleased to make amends at the earliest possible opportunity.

University of Cambridge International Examinations is part of the Cambridge Assessment Group. Cambridge Assessment is the brand name of University of Cambridge Local Examinations Syndicate (UCLES), which is itself a department of the University of Cambridge.

5054/03/C1/O/N/08

This form must be completed and returned with the Answer Booklets.

REPORT ON PRACTICAL PHYSICS

The Supervisor is asked to give the following details, using the space provided on page 12.

- (a) Information required at the end of the test, as indicated in the Instructions.
- (b) Any help given to a candidate.
- (c) Any general difficulties encountered in preparing the apparatus.
- (d) Any difficulties experienced by particular candidates. These should include reference to difficulties due to faulty apparatus or materials and accidental damage to apparatus or materials. Candidates should be identified by name and candidate number.

Other cases of hardship, such as disability or illness, should be reported to the Syndicate in the normal way.

The Supervisor is asked to provide a plan of the work benches, giving details by candidate numbers of the places occupied by the candidates for each session. The plan should be enclosed with the Answer Booklets, together with the information required by Examiners.

Declaration to be signed by the Principal

The preparation of this practical examination has been carried out so as fully to maintain the security of the examination.

Signed

Name (in block capitals)

Centre Number

Centre Name



Information required

None.

Details of difficulties and any help given to candidates

